

CONCORDE

EMMANUEL GALLINA (2009)



DESCRIPTION

A design able to propose a primary shape, emphasizing the naturalness of the wood for Concorde table by Emmanuel Gallina. Soft shapes interpreted with essential style.

Poliform

CONCORDE

EMMANUEL GALLINA (2009)

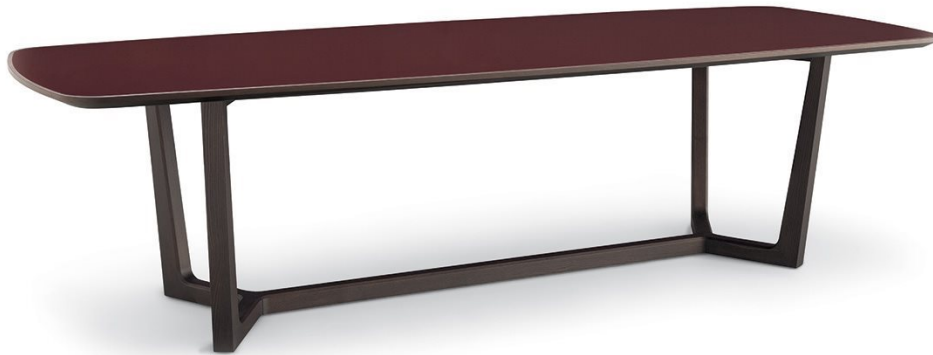

TECHNICAL DESCRIPTION

TYOLOGY

fixed table

LEGS

solid wood

TOP

available in wood, marble or wood frame with insert in glass. Optional spinning tray only available for round tables

CONCORDE

EMMANUEL GALLINA (2009)

TCN218

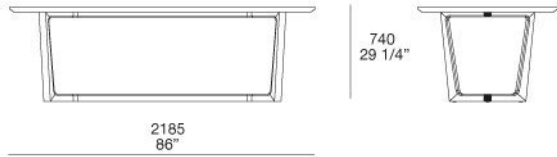

TCN240

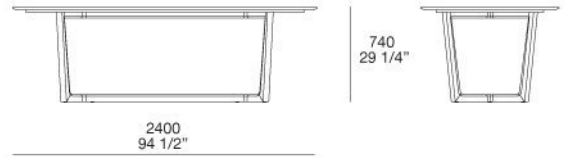

TCN280

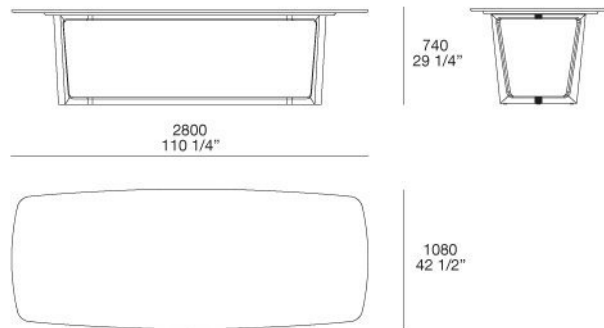

TCN140R

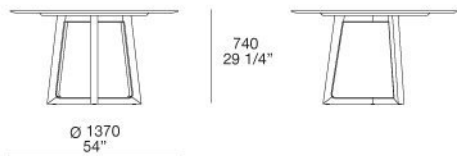

**TCN180R
PG090**

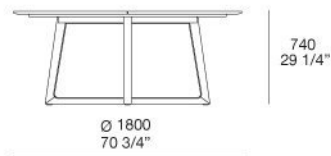

**TCN200R
PG105**

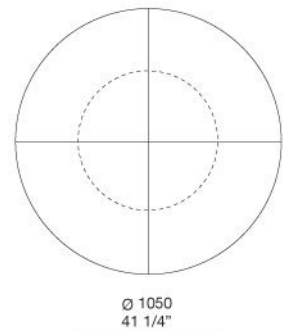
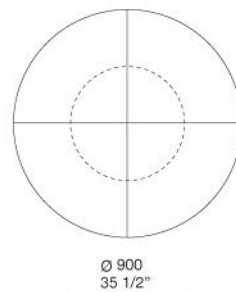
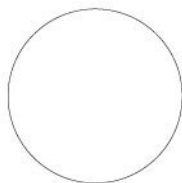
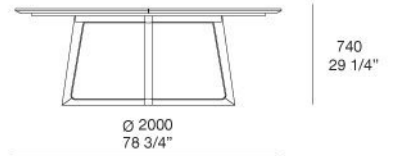

Poliform

CONCORDE

FINISHINGS\TOP\MARBLE (10)

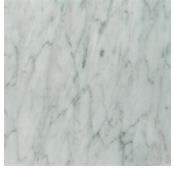

MATT
BIANCO
CARRARA

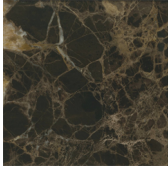

MATT
EMPERADOR

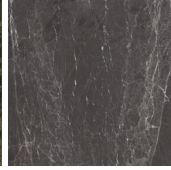

MATT GREY
STARDUST



MATT
CALACATTA
ORO



GLOSSY
BIANCO
CARRARA

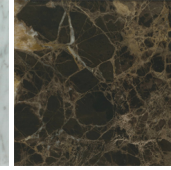

GLOSSY
EMPERADOR

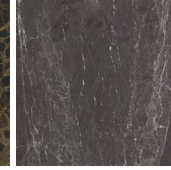

GLOSSY
GREY
STARDUST

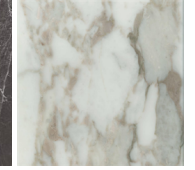

GLOSSY
CALACATTA
ORO



GLOSSY
NOIR SAINT
LAURENT



MATT
SAHARA
NOIR

CONCORDE

FINISHINGS\TOP\REFLECTING GLASS (1)



5010 BLUE

CONCORDE

FINISHINGS\TOP\VETRO CONCORDE (4)



2273
GHIACCIO
GLOSSY

1264 ARENA
GLOSSY

1204
GRAFITE
GLOSSY

2259
BORDEAUX
GLOSSY

CONCORDE

FINISHINGS\TOP\WOODS (4)

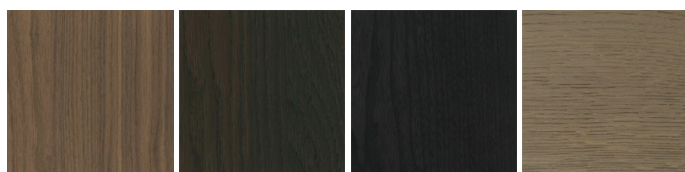

WALNUT C.

SPESSART
OAK

BLACK ELM

CENERE OAK

CONCORDE

FINISHINGS\STRUCTURE\WOODS (3)

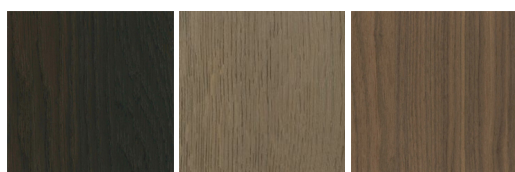

SPESSART
OAK

CENERE OAK

WALNUT C.

CONCORDE

FINISHINGS\STRUCTURE\WOODS (1)

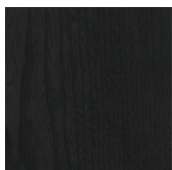

BLACK ELM